



GAS

ELEMENTS SERIES RANGES

IMPERIAL



ER-6

Shown with optional casters

MODELS:
ER-4
ER-6
ER-10
ER-6-G24

ER-6-G24

Shown with optional casters



GRIDDLE

- Highly polished 1/2" (12.7 mm) steel plate. 21" (533 mm) plate depth.
- Burners have 15,000 (4 KW) BTU/hr. output with a heat deflector every 12" (305) for even heating.
- 3" (76 mm) wide grease trough and removable grease can for easy cleaning.
- Large griddle grease can and full width broiler drip tray are removable for easy cleaning.

OPEN BURNERS

- 28,000 BTU (8 KW) burner low simmer feature.
- Two rings of flame for even heating.
- Cast iron burners are standard on all Elements Series
- Burners lift off for easy cleaning. No gaskets or screws.
- One standing pilot per burner for instant ignition.

EXTERIOR FEATURES

- Stainless steel front, backguard, shelf, landing ledge, kick plate and aluminized steel sides
- Large 5" (127 mm) stainless steel landing ledge
- Control knobs are plastic durable
- Full width, removable crumb tray under open burners for easy cleaning

STANDARD OVEN

- Straight full port burner provides even heating throughout the oven.
- Large flame spreader that distributes heat flow evenly throughout the oven cavity.
- Chef Depth interior is 26-1/2" w x 26" d x 14" h (673 w x 660 d x 356 h mm) and accommodates 18" x 26" (457 x 660 mm) sheet pans left-to-right and front-to-back.
- Oven 35,000 BTU (10 KW).
- ER-4 features Space Saver Oven with 27,000 BTU (8 KW).
- Aluminized sides, rear, top and door lining
- Porcelainized oven bottom liner for easy cleaning.
- Heavy duty door hinge.
- One chrome oven rack is included.

GRATES

- Front and back grates measure 12" x 12" (305 x 279 mm).
- Grates are sized for positioning large stock pots directly over burner and feature a hot air dam.
- Pots slide easily from section to section and onto landing ledge.
- Grates are cast iron for a long service life.



1128 Sherborn Street | Corona, CA 92879 | 800.343.7790 | imperialrange.com | imperialsales@imperialrange.com

© 2026 Imperial Commercial Cooking Equipment Imperial reserves the right to change specifications at any time without prior notice and without any obligation for past or future equipment purchases. Visit www.imperialrange.com for specification updates



GAS

ELEMENTS SERIES RANGES

ER-6

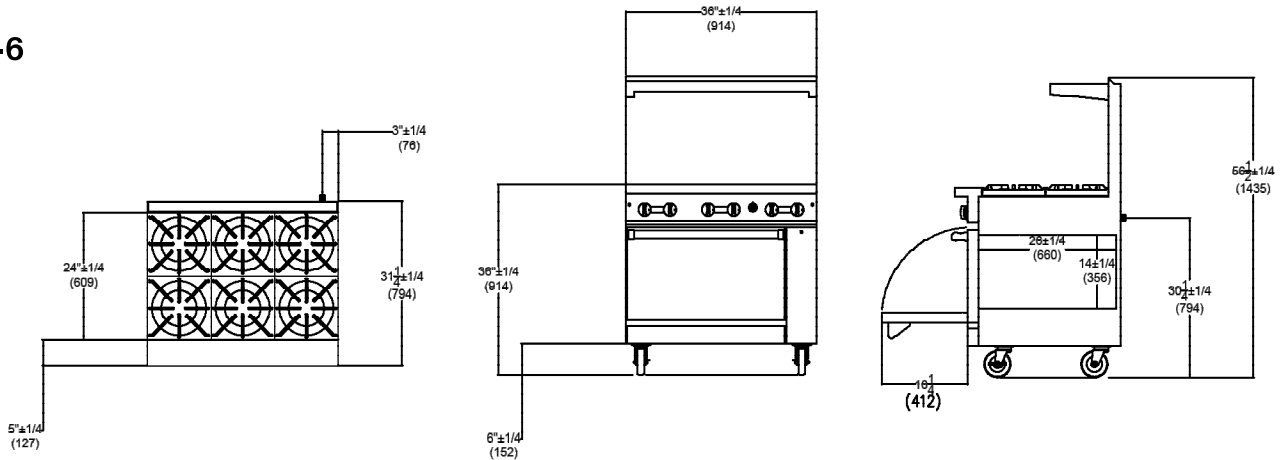

ER-6-G24

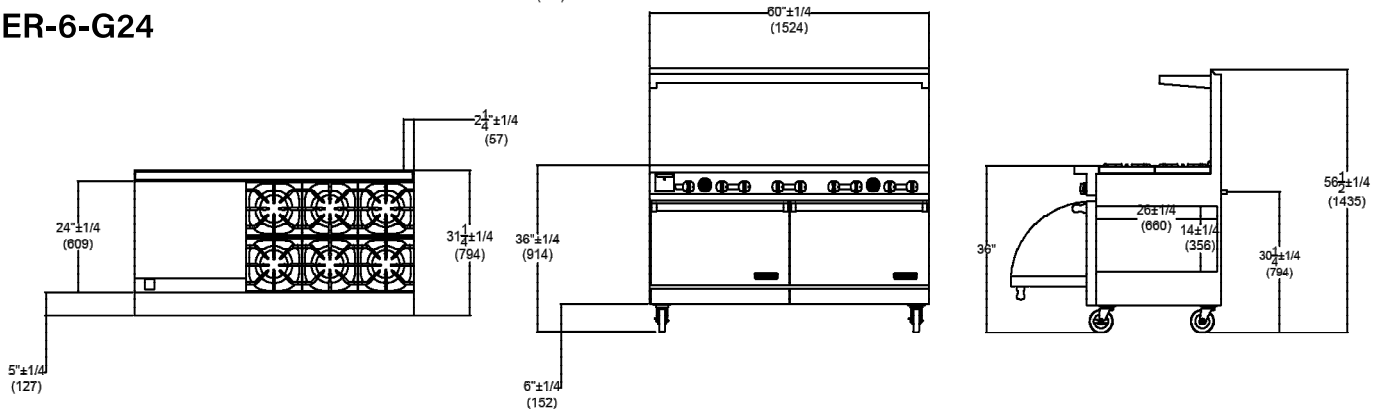

MODEL	GAS OUTPUT		OPEN BURNERS	GRIDDLE WIDTH (MM) IN	SHIP WEIGHT (KG) LBS	DIMENSIONS	CRATED DIMENTIONS
	BTU'S	KW'S					
ER-4	139,000	41	4		(120) 265	24 x 34 1/4 x 56 1/2 (610 x 895 x 1435)	26 x 41 x 36 (660 x 1041 x 914)
ER-6	203,000	60	6		(181) 398	36 x 34 1/4 x 56 1/2 (914 x 895 x 1435)	38 x 41 x 36 (965 x 1041 x 914)
ER-10	350,000	103	10		(301) 663	60 x 34 1/4 x 56 1/2 (1524 x 895 x 1435)	62 x 41 x 36 (1575 x 1041 x 914)
ER-6-G24	268,000	79	6	(610) 24"	(309) 682	60 x 34 1/4 x 56 1/2 (1524 x 895 x 1435)	62 x 41 x 36 (1575 x 1041 x 914)

Notes: Measurements in () are metric equivalents.

CLEARANCE REQUIREMENTS

For use only on non-combustible floors. Legs or casters are required for non-combustible floors; or 2" (51 mm) overhang is required when curb mounted. Provide 0" clearance from non-combustible surfaces and 6" (152 mm) from combustible surfaces.



MADE IN USA



1128 Sherborn Street | Corona, CA 92879 | 800.343.7790 | imperialrange.com | imperialsales@imperialrange.com

© 2026 Imperial Commercial Cooking Equipment Imperial reserves the right to change specifications at any time without prior notice and without any obligation for past or future equipment purchases. Visit www.imperialrange.com for specification updates